

DO NOT SCALE DRAWING REPORT ALL DIMENSIONS TO THE DEPT.
TOLERANCES TWO DECIMALS ± .00
THREE DECIMALS ± .00

REVISIONS				
ZONE	No.	DESCRIPTION	DATE	BY
Δ				

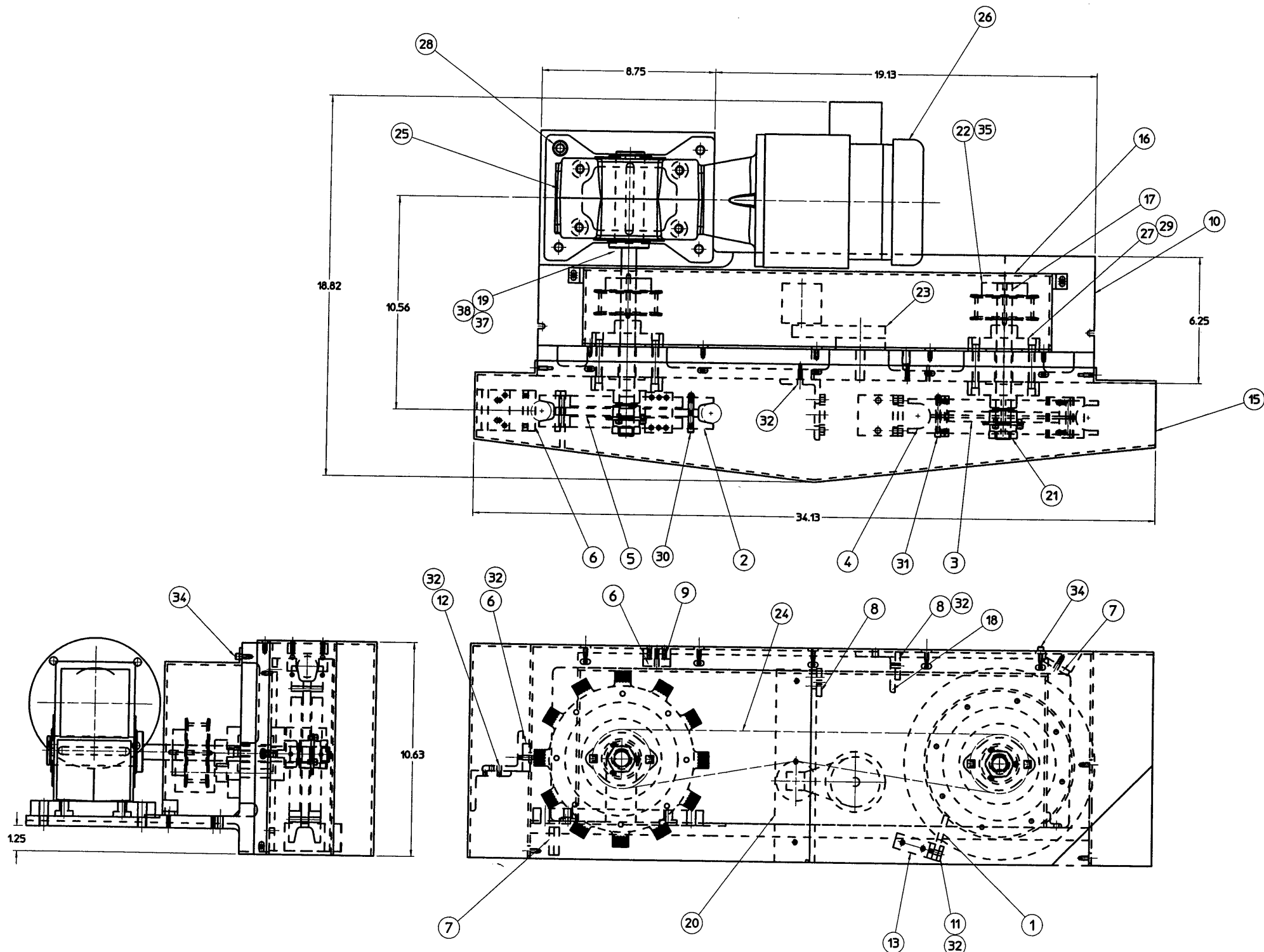

38	2	RETAINING RING	PURCH
37	1	3/8 X 3/8 X 4.00 LG	KEY STOCK
35	2	3/16 X 3/16 X 2.00 LG	KEY STOCK
34	16	#10-24 X .50 SOC HD CAP SCREW	SST
		WITH F/W, L/W	
33	2	#10-24 X 1.00 SOC HD CAP SCREW	SST
		WITH F/W, L/W & HEX NUT	
32	10	#10-24 X .75 SOC HD CAP SCREW	SST
		WITH F/L & L/W	
31	8	#10-24 X 2.25 SOC HD CAP SCREW	SST
		WITH F/W, L/W & HEX NUT	
30	8	#10-24 X 2.00 SOC HD CAP SCREW	SST
		WITH F/W, L/W & HEX NUT	
29	8	5/16-18 X 1.25 SOC HD CAP SCREW	SST
		WITH L/W	
28	4	7/16-14 X 1.25 SOC HD CAP SCREW	SST
		WITH L/W	
27	4	FLANGE BEARING	PURCH
26	1	1/2 HP ELECTRIC MOTOR	PURCH
		1800 RPM FRAME 56C 115/230-60HZ	
		1PH TEFC	
25	1	REDUCER	PURCH
24	1	BELT	PURCH
23	1	TENSIONER	PURCH
22	2	BELT SPROKET	PURCH
21	2	TAPERED KEYLES BUSHING	PURCH
D2020	20	1 BRACKET	6061 ALUM
D2019	19	1 REDUCER SHAFT	TG & P
D2018	18	1 BRACKET	6061 ALUM
D2017	17	1 SHAFT	CFS 1018
D2016	16	1 GUARD REAR SAFTY GUARD	FAB ALUM
D2015	15	1 GUARD FRONT SAFTY	FAB ALUM
B2014	13	1 BRACKET	6061 ALUM
B2012	12	1 BRACKET	6061 ALUM
A2011	11	1 RETAINER	6061 ALUM
D2010	10	1 BASE	CAST ALUM
A2021	9	1 SPACER	6061 ALUM
A2008	8	2 SCRAPER	DUREON
A2006/AC	7	2 PRESSURE PAD BLOCK	DUREON
A2006/AB	6	2 PRESSURE PAD BLOCK	DUREON
D2005	5	1 DRIVE WHEEL HUB	6061 ALUM
D2004	4	2 PULLY WHEEL UNIVERSAL RING	DUREON
D2003	3	1 PULLY WHEEL HUB	6061 ALUM
D2002	2	2 DRIVE WHEEL RING	DUREON
A2001	1	1 PULLY WHEEL SCRAPER	URETHANE MATERIAL

MODEL BG01 SKIMALLTM OIL SKIMMER

NO.	DATE	BY
3	01 29 03	NC
2	01 29 03	NC
1		

SKIMTECH
THE SKIMTECH CORPORATION BOARDMAN, OHIO U.S.A.

1' DIA. SKIMALL ASS'Y SPARE LIST
MATERIAL FAB STEEL

SIZE **D 3024**
SCALE 0.38 SHEET 1 OF 1